



RR400/420 Regularity timer getting started



Tips and tricks

Firmware version 190122

Friday, April 05, 2019

CRISARTECH
+33 (0)5.63.93.25.24
www.crisartech.com

C. MARQUES
christophe.marques@crisartech.com

Important: videos explaining the operation of the device can be viewed and downloaded on the page:

<http://www.crisartech.com/fr/rr400.html>

or *Youtube channel* **CRISARTECH**:

<https://www.youtube.com/user/CRISARTECH>

The latest program and documentation updates can be found on this page:

http://www.crisartech.fr/download/rr400_fr.html

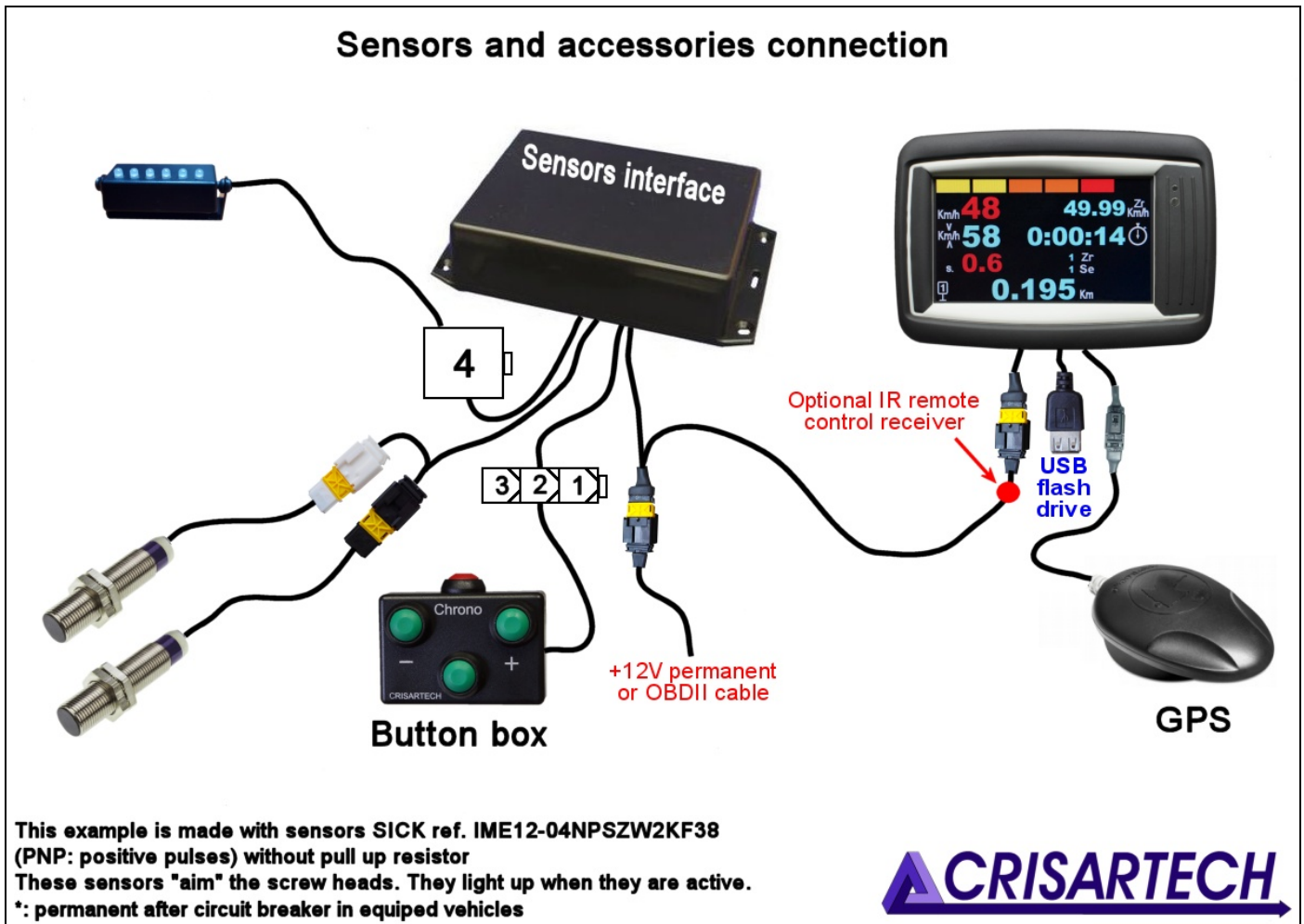

Table of Contents

1	CONNECTIONS	4
1.1	RR400 (WITH SEPARATE INTERFACE)	4
1.2	RR420 (WITH INTEGRATED INTERFACE, BEHIND DISPLAY).....	7
2	BASIC PRINCIPLES	9
3	FORWARD / REVERSE, STOP	10
4	MAIN MENU	11
5	VEHICLE TYPE CONFIGURATION, TESTS, CALIBRATION...	12
5.1	VEHICLE TYPE CONFIGURATION	12
5.1.1	<i>Type of connection choice</i>	12
5.1.2	<i>Left or Right wheel choice</i>	13
5.2	SENSORS TEST	13
5.3	CALIBRATION.....	14
5.4	SIMULTANEOUS CALIBRATION OF THE GPS	15
5.5	CALIBRATION ADJUSTMENT	15
5.6	CALIBRATION HISTORY	16
5.7	WHEEL SENSOR MONITORING.....	16
5.8	BATTERY VOLTAGE MONITORING	17
6	OPERATING MODES	18
6.1	BEGINNER.....	18
6.2	CONFIRMED	18
6.3	EXPERT.....	18
7	USB DRIVE USAGE	18
8	INFRARED REMOTE CONTROL	19
8.1	FREEZE / CHANGE DISTANCE	19
8.2	NEW DISTANCE	20
8.3	MANAGING ZRS WITH THE REMOTE CONTROL	20
9	ENTERING A DISTANCE ON THE FLY	21
10	SHIFTED START	22
10.1	FUNCTION ACTIVATION	22
10.2	AVERAGE SPEEDS CHANGES SINCE THE BEGINNING OF THE ROAD BOOK	22
10.3	AVERAGE SPEEDS CHANGES SINCE THE BEGINNING OF THE RT	22
11	MULTISPEEDS MODE	23
12	RECORDINGS	24
12.1	REGULARITY TESTS RECORDING	24
12.2	GPS TRACE DURING SCOUTING	25
12.2.1	<i>Traces with fixed distance</i>	25
12.2.2	<i>Traces with fixed time (0.1 second)</i>	25
12.3	CORRECTION WAYPOINTS DURING SCOUTING.....	25
12.4	FILE COPYING AND ARCHIVING.....	26
13	“GRAVEL CREW” NOTES ANNOUNCEMENT	27
14	FIRMWARE UPDATES	28
15	WELCOME PICTURE UPDATE	29

1 Connections

1.1 RR400 (with separate interface)



Warning: the interface provides a power supply for the sensors which is protected by a fuse. A fuse holder is located on the side of the housing. A 200 mA fuse is supplied as standard (plus a replacement fuse). This value is suitable for most sensors on the market, but it is up to the installer to check if it is correct for sensors other than those supplied by CRISARTECH.

The harness for connection to power supply can be replaced by the OBDII harness that plugs into a modern vehicle (after about 2006).

4 ways connector for power supply and CAN bus:

Contact name	Remark	Num.	Colour old car	Colour modern car
+12V permanent power		1/4 M	Brown	Red
Ground		2/4 M	Black	Blue
CAN H on ODBII		3/4 M	/	Yellow
CAN L on ODBII		4/4 M	/	Green

3 ways connecteur - BLACK for RIGHT wheel sensor:

Contact name	Remark	Num.	Colour
+12V power for sensor	on fuse holder	1/3 F	Red
Ground for sensor		2/3 F	Blue
R wheel signal		3/3 F	Green

3 ways connecteur - WHITE for LEFT wheel sensor:

Contact name	Remark	Num.	Colour
+12V power for sensor	on fuse holder	1/3 F	Red
Ground for sensor		2/3 F	Blue
L wheel signal		3/3 F	Green

Tip for connectors with crimping pins:

- use crimping pliers for pins rather than welding,
- reinforce the output of the wires with adhesive lined heatshrink Tub (more rigid),
- these "automotive" connectors have a double locking system: when the spindle is fitted, a small click is heard: first locking. Once all the pins are in place, the second system must be locked:
 - o yellow plastic part for male connectors,
 - o Lid of the same color for females.

If one of the pins is not in place, it is not possible to close the second lock. If this second locking is not properly installed, the connector can not be connected.

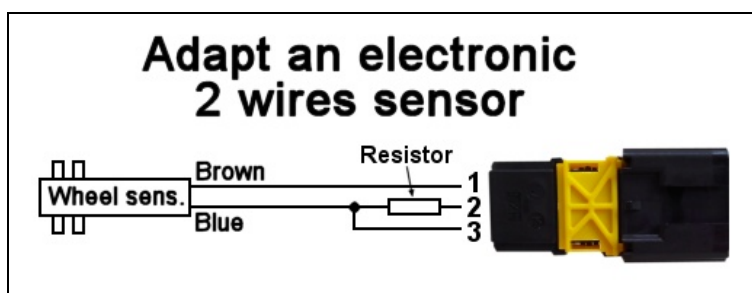
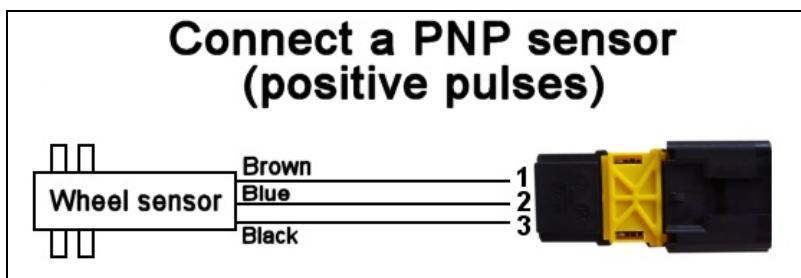
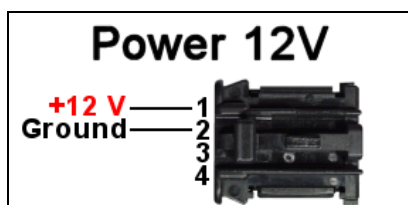

The resistance to put between the blue wire and the mass is 750 Ohms 1/4 watt for the sensors:

- Blunik Carlo Gavazzi inductive,
- Inductive Terratrip T005 ...

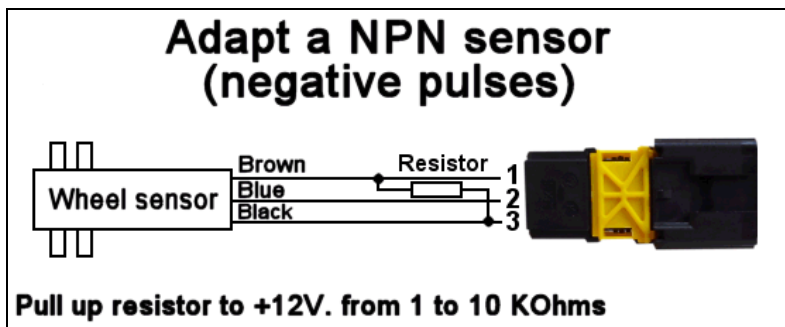
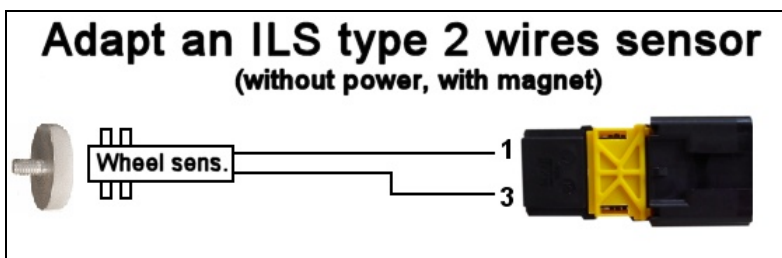

The optional "pilot" display connects to the 4-pin connector located to the power supply:

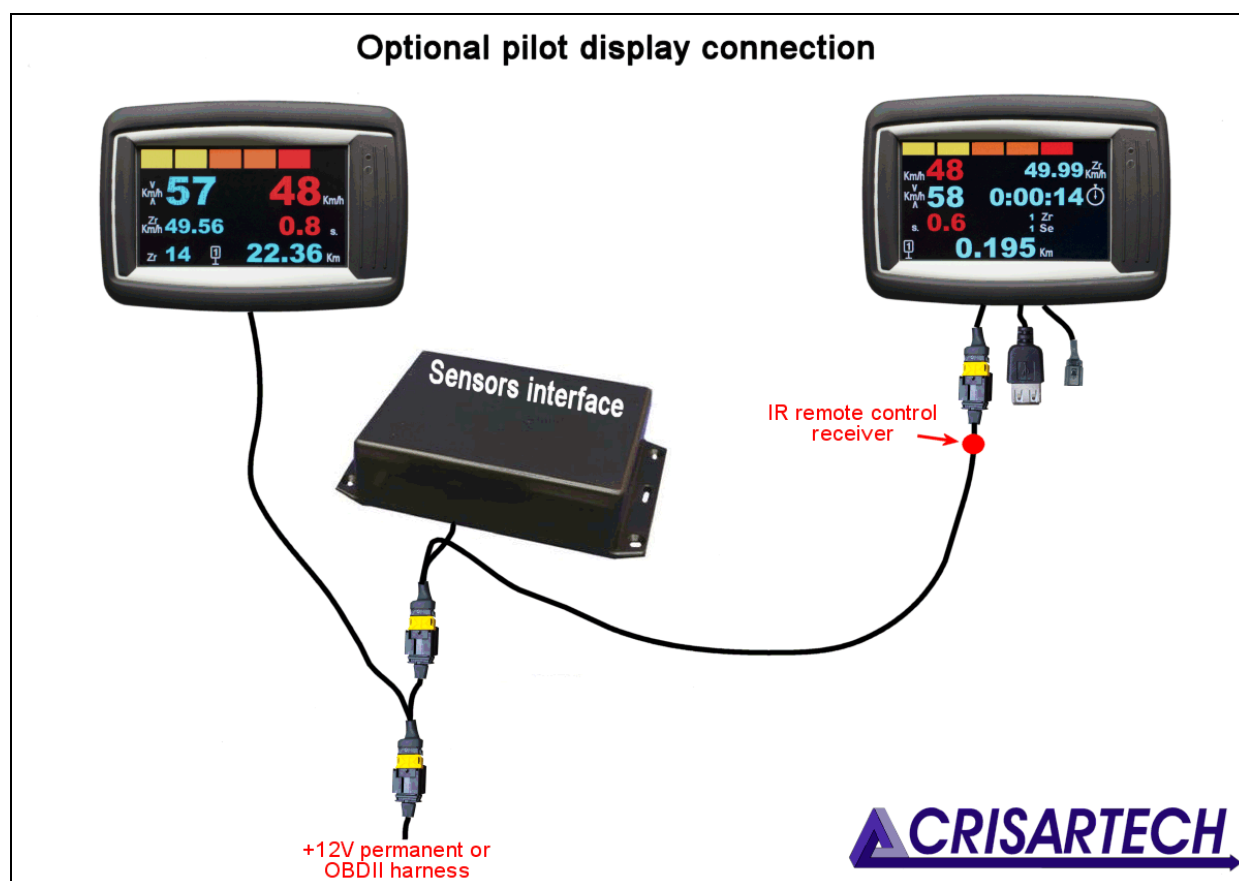

Caution: the infrared receiver for remote control is placed on the harness, just below the display connector. It must be ensured that lens is not masked and turned towards the co-pilot so that the infrared remote control is fully operational.

1.2 RR420 (with integrated interface, behind display)



Important: the plastic case manufactured by 3D printing **does not withstand the temperature that can be found in a closed car, under a windshield, in the summer sun.** Therefore, if your car must stay parked in the sun, we advise you:

- remove the RR420 from the vehicle or place it in a cooler place (trunk ...),
- if this is not possible, turn off the RR420 and use a solar ray reflector (metallized accordion placed under or better on the windshield) and leave the windows open,
- in last resort, turn off the RR420, place a white cloth on the RR420 and leave the windows open,
- **do not leave the cloth on the RR420 during use.**

Connections:



Led6 Pilot display Power Left sensor Right sensor Button box GPS Audio repeater

"Universal" 4-wire harness connected to 2-wires sensor (gray connector, 4-pin):

+12V	1	Red	Red	Red	Usually sensor brown wire
Ground	2	Blue	Black	Black	Not connected
Signal	3	Green	Orange	Orange	Not connected
Ground -Signal	4	Yellow	Yellow	Brown	Usually sensor blue wire

"Universal" 4-wire harness connected to 3-wires sensor (gray connector, 4-pin):

+12V	1	Red	Red	Red	Usually sensor brown wire
Ground	2	Blue	Black	Black	Usually sensor blue wire
Signal	3	Green	Orange	Orange	Usually sensor black wire
Ground -Signal	4	Yellow	Yellow	Brown	Not connected

Harness for 3-wires sensor (gray connector, 4 points):

+12V	1	Red		Usually sensor brown wire
Ground	2	Blue		Usually sensor blue wire
Signal	3	Green		Usually sensor black wire

Beam for 2-wires sensor (gray connector, 4 points):

+12V	1	Brown		Usually sensor brown wire
Ground -Signal	4	Black		Usually sensor blue wire

Power harness (black / blue connector, 4 points):

+12V	1	Red	Brown	Red
Ground	2	Black	Black	Blue

Note: The RR420 provides a power supply for sensors that is protected by an automatically resettable fuse. There is nothing to do in case of a short circuit.

2 Basic principles

This timer uses a touch screen for the configuration, calibration, speed input ...

To modify an item, press the item zone. In "beginner" mode, the user is guided by a grid that indicates the different sensitive zones:

- "chrono"
- "trip"
- 'ZR'
- "correction cancellation"...

The page change is made by pressing outside these areas, next page on the right and previous on the left, in blue and green respectively on the following images:



buttons allow you to go back, exit the configuration pages...



Warning: if a parameter has been modified, the modification is saved!

Do not forget to use the **help buttons** when in doubt (except expert mode):



3 Forward / Reverse, Stop

To access the RND panel (analogy to the automatic gearboxes):

- press the screen (top-middle of preference) then on the button **RND** that appears in the top left,
- press the  key on remote control Philips or  key on the "one for all"



- **R** for "Reverse"
- **N** for "Neutral" or stop counting,
- **D** for "Drive" or Forward.

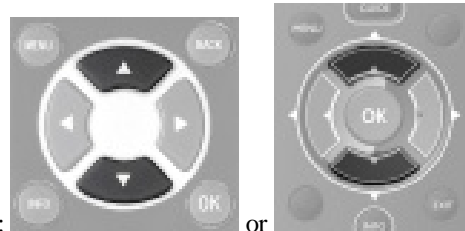

Then press the desired operating mode or use remote control:

This panel will only be displayed when the position is different from "Drive".

Special case in GPS measurement:

Tunneling is a serious problem because the signal is gradually lost and the speed transmitted by the GPS becomes erroneous before the signal is lost. To avoid this, it is possible to block the speed before entering the tunnel. By driving at constant speed, it is possible to cross the tunnel without too much distance error. The manipulations to do are the following:

- display the above sign before arriving in the tunnel,
- press D to block the speed and display the following panel:



- cross the tunnel at the most stable speed possible,
- when leaving, press again on this panel to resume the GPS speed.

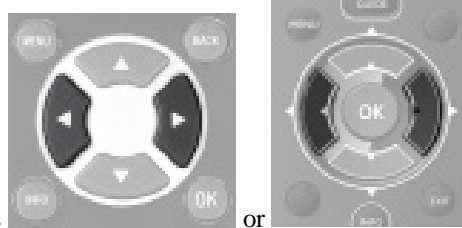

Note: with remote control: press  or  to lock / unlock GPS speed.

4 Main menu

To access the main menu, press the screen (top, middle preferably) and then the yellow button that appears:



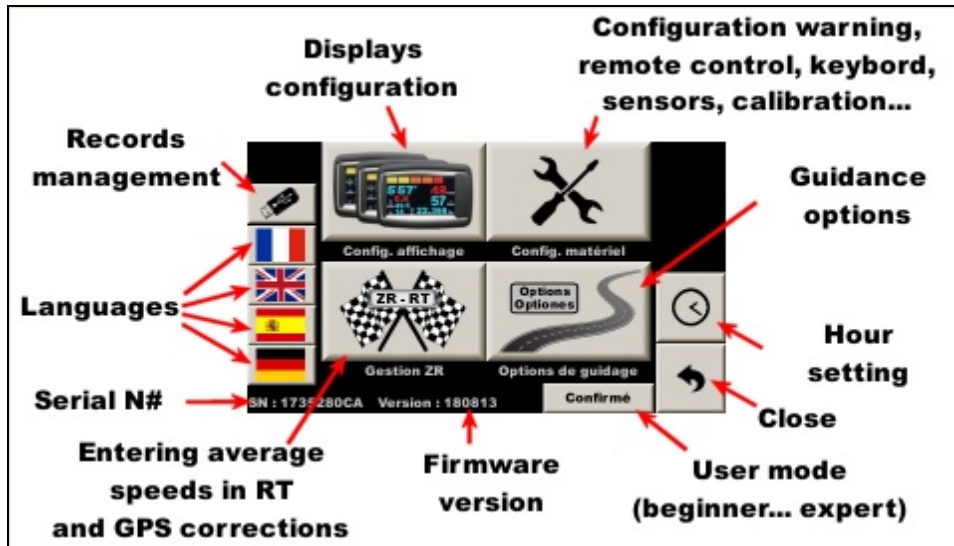

5 Vehicle type configuration, tests, calibration...

In the main menu, press the button with tools:



5.1 Vehicle type configuration

In the following menu, press the button with auto and ruler:



5.1.1 Type of connection choice

Start by choosing the type of connection:

- **GPS** (not very accurate),
- **OBDII** (diagnostic socket), then the vehicle type. Those marked "ABS" have a very precise measurement of the distance (from 1 to 10 cm). "Obd 11 bits" and "Obd 29 bits" are *universal* but not very accurate (1 to 3 m error per km). This precision is sufficient in the race because it is negligible in relation to the trajectories cut but insufficient for the measurements carried out for creating road-books or scouting,
- **wheel speed sensor** (s). Three configurations (A, B, and C) are proposed, corresponding to **3 different types of tires**. This makes possible to memorize in the device 3 calibration values that will be associated with each type of tire. By changing the wheel during the race, simply change the configuration here, without having to change the value by itself,
- **speed simulation** (speed is set with two buttons).

These points can be "swept" using the **up** and **down** arrow keys on the remote control. In **OBDII** configuration, the **red** and **blue** function keys are used to select the type of vehicle.

5.1.2 Left or Right wheel choice

When possible, a panel at the bottom of the screen can then choose whether the distance should be **measured on the right / left / average** of the two wheels.

These choices can be "swept" using the **left** and **right** arrow keys on the remote control.

Note:

- with "Peugeot/Citroën ABS" OBDII configuration **4WR** check box add 2 more wheel inputs (front wheels),
- with the **Capteur/sensor** configuration, two checkbox add the sensor monitoring function based on the GPS (**Compare GPS**), or on left/right wheel sensor comparison (**Compare L/R**), see below.
- Then go to the "**Calibration**" tab (**Page** key on remote control).

Remote control usage:

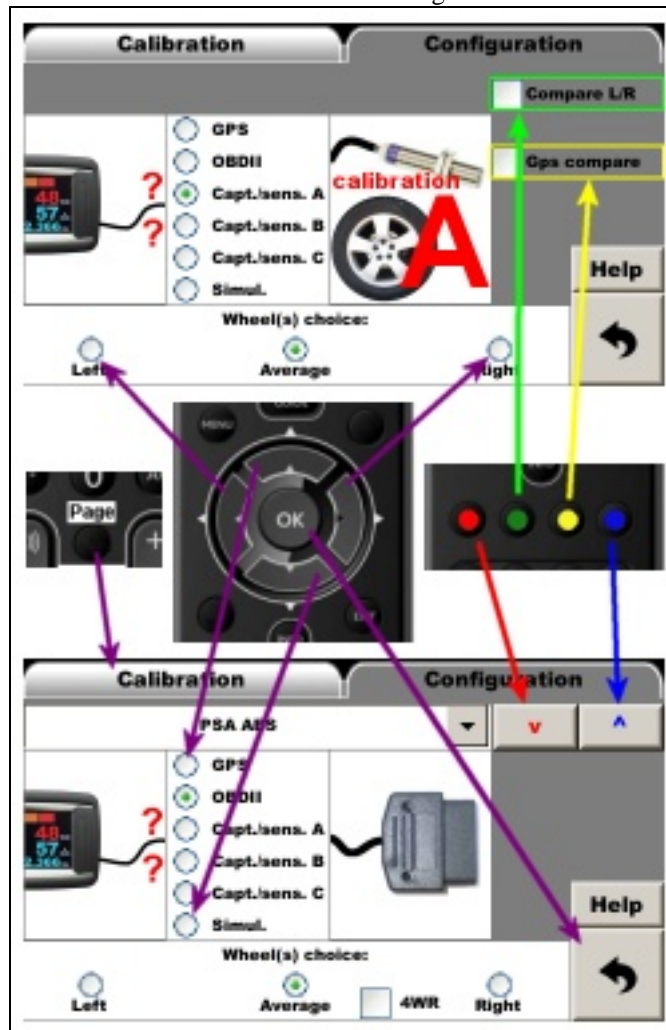

5.2 Sensors test

If the system allows it (wheel speed sensor or OBDII in ABS mode), the **Detailed distances** button displays the pulses sent by the sensors via the page (the number of counters can be different according to the configuration):

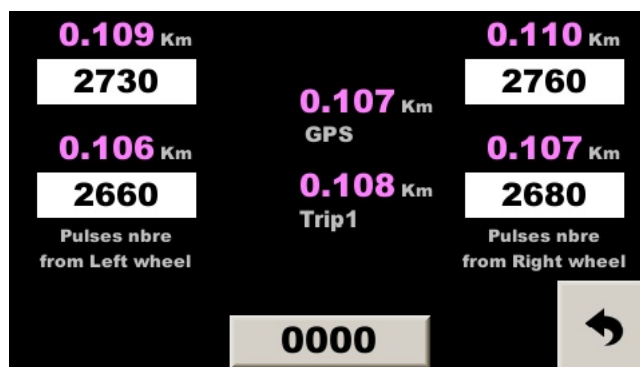

This page help to compare all the wheel “sensors”, the distance calculated for each wheel, the GPS distance calculated and Trip1, based on the configuration and the above distances

In case the timer is connected to wheel speed sensor (s), first check that each pulse increments the counter of the rotating wheel.

At the end of the installation, before calibration, carry out a **test by accelerating progressively up to the maximum speed** of the vehicle. The displayed speed must be stable (even if it is false because not yet calibrated).

If this is not the case, the speed sensor(s) are incorrectly adjusted:

- if the speed tends to fall to 0 beyond a certain speed, the sensor misses tops at high speed, it must be too far from the "target" or "target" is not of good "ferromagnetic quality",
- if the speed tends to double at certain times, the sensor records "rebounds". This can happen with ILS sensors when they are too close to a very powerful magnet. Or problems of false contacts

5.3 Calibration

Once measurement configuration has been chosen (GPS, OBDII, or sensor), it is necessary to calibrate for your device measures the distances precisely, but especially in the same way as that of the organizer. The RR400 uses a very precise calibration coefficient. Or rather several coefficients:

- calibration coefficient when the measurement is made by GPS (the value is about 1),
- calibration coefficient when the measurement is made by the OBDII socket (the value is about 1),
- 3 calibration coefficients when the measurement is made by the wheel speed sensor (the value corresponds to the distance of a sensor top, ie the perimeter of the wheel divided by the number of tops per revolution), one coefficient for each tyre type (A, B or C),
- calibration coefficient when the speed is simulated (the value is about 1).

But this coefficient is then used to measure ALL distances (Trip1 to Trip3, and Totalizer)

On the calibration page, select the calibration **mode**:

- **Trip1** uses the first counter to perform the calibration. This is the default mode, the simplest,
- **Trip2** uses the second counter to perform the calibration. Used to calibrate (or refine calibration) during the first ZR. In this case the Trip1 was used and adjusted during the ZR, so not usable to calibrate. Trip2, on the other hand, has not been modified and can be used to calibrate at the end of ZR, using the theoretical distance written on the road-book. The advantage is to have a distance generally longer than the calibration zone and taking into account the cut curves (driving style),
- **Free calcul**: here only the function of "special calculator with rule of proportionality " is used: calculation of the calibration from a distance that has been measured before and the corresponding theoretical distance,
- **GPS**: to perform a **rapid calibration** of the speed sensors, we use the GPS speed. This method does not have the precision required to perform a rally, but allows a quick calibration after the sensor test. This allows you to have a correct speed displayed in the main page without needing to go on a calibration zone, but **does not replace in any case a real calibration at the beginning of the rally.**

Typical case of Trip1:

- drive to the beginning of the calibration zone,
- press button "0.000"
- drive to the end of calibration zone, the distance is displayed in the left field,
- enter the zone theoretical distance in the right field,
- then press the **"Compute"** button: the new value is displayed next to it.

Congratulations, it's over!

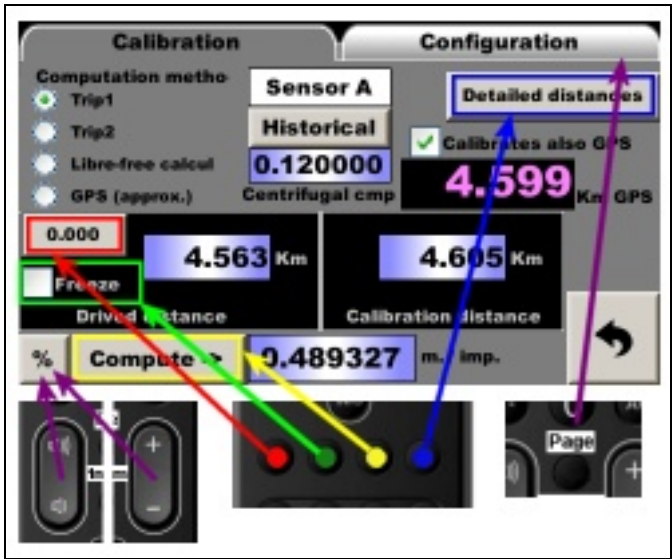

5.4 Simultaneous calibration of the GPS

When one or more speed sensors are used to measure the distance, the GPS can be used as a backup measurement means in case of failure of the sensor (s). For this purpose, the GPS must be calibrated in the same way as the speed sensors. On the calibration area, just check the box: **Calibrates also GPS**

By calculating the calibration coefficient of the speed sensors, the RR400 calculates the calibration coefficient of the GPS and displays it in an information panel. It must be close to 1.

5.5 Calibration adjustment

If the co-pilot realizes that his calibration is not optimal, he can easily adjust it in percentage (except beginner mode). In the calibration screen, the button opens a window allowing this adjustment:

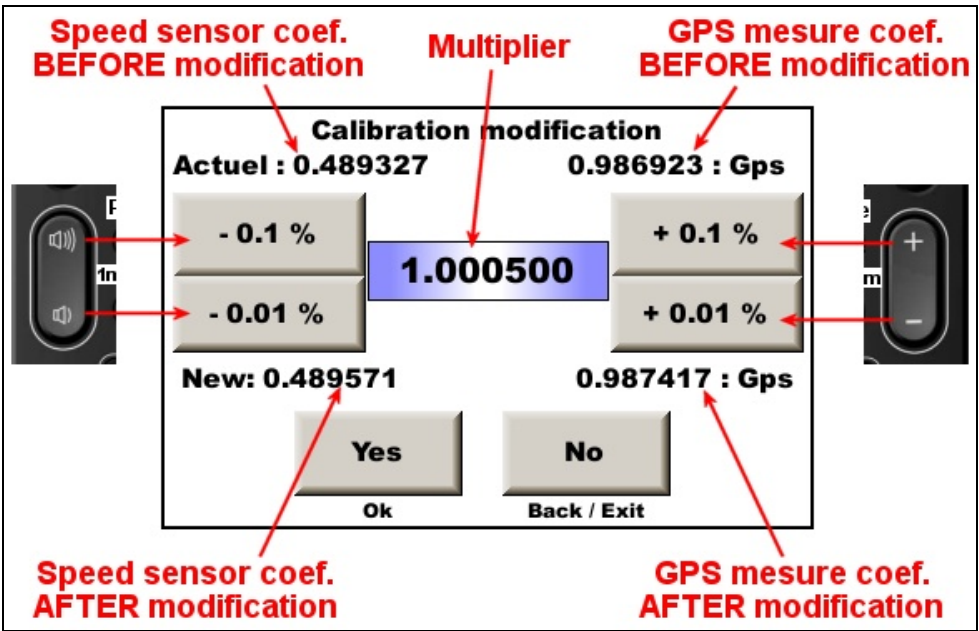

For memory, here are the percentages or coefficients to apply according to the desired corrections:

number of m. / Km to correct	% of correction	multiplier coefficient to apply
10	1	1.01
5	0.5	1.005
1	0.1	1.001
0.5	0.05	1.0005
-0.5	-0.05	0.9995
-1	-0.1	0.999
-5	-0.5	0.995
-10	-1	0.99

5.6 Calibration history

The button  is used to display a table of the different calibration values calculated on the device:

Date – hour	Source	Method	Calibration
2018/09/01-07:24	OBD	MAN	1.025399
2018/09/01-07:28	GPS	MAN	0.9869231
2018/09/01-07:31	Sensor A	MAN	0.4893265
2018/09/05-16:08	Sensor A	%	0.4895712
2018/09/05-16:08	Sensor A	MAN	0.4895712
2018/09/05-16:08	Sensor A	TRIP1	0.4886692
2018/09/05-16:08	Sensor A	MAN	0.4886692
2018/09/05-16:08	Sensor A	TRIP2	0.4893671
2018/09/05-16:09	Sensor A	MAN	0.4893671
2018/09/05-16:09	Sensor A	FREE	0.4898044
2018/09/05-16:10	Sensor A	GPS	0.4895166

The **Source** column corresponds to the input selected to calculate distances that has been calibrated (**GPS, OBDII, Sensor A, B, C** or simulation).

The **Method** column recalls which method was used to change the calibration:

- **MAN**: the calibration value was entered directly with the keyboard,
- **TRIP1** or **TRIP2**: the value has been calculated on a calibration zone,
- **FREE**: the value has been freely calculated based on a distance traveled and a reference distance,
- **GPS**: the value was calculated approximately using GPS speed,
- **%**: the value has been adjusted by percentage.

Note: during TRIP1, 2 or FREE calculations, the value before calculation is recalled on the top line in **MAN**.

The button  deletes the table.

The file containing these data is copied to the USB drive at the same time as the race recordings and can be archived with this data.

5.7 Wheel sensor monitoring

Specifically for the **Captteur/sensor** configuration it is possible to activate the sensor signal monitoring function by ticking the **Compare GPS** or **Compare L/R** box in the configuration tab of the input used for speed measurement. The distances measured by the sensors left and right and/or the GPS are compared and if a significant difference appears, an alert popup is displayed in the main running screens:



The red LED flashes if the corresponding box is checked in the alert configuration screen:

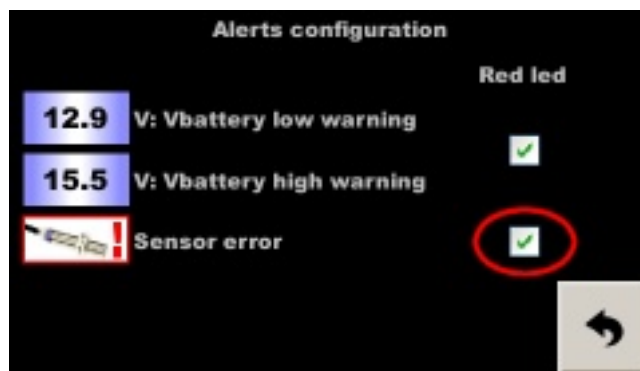

Menu - Config. equipment - Alerts config.

By removing this popup, we can display the percentages of error, which allows to better understand the problem:

- if a slight difference appears between right and left, following a succession of turns in the same direction, we can consider that it is a false alarm, but it is necessary to monitor the / the sensors,
- **if a slight difference appears after changing tires, you must change the calibration,**
- if a difference with GPS appears after having crossed a tunnel, an avalanche barrier, or a very dense forest, it is normal the GPS lost some meters,
- **if a significant difference suddenly appears, a sensor may be faulty, especially not perform “on-the-fly” correction (+/- 1 or 10 m key) before confirming or reversing this assumption.** To do this, go to the detailed distances page to monitor the distances of each sensor. If the failure of one sensor is confirmed, use the other or the GPS. The most correct distance will be restored automatically when the faulty sensor is ignored, because the distances (L wheel, R wheel and GPS) are measured separately, then selected or averaged to serve Trip1. But during a correction, the three are synchronized, that's why we must not correct “on the fly” when we have a doubt.

	<u>action on the touch screen:</u>	<u>action on the remote control:</u>	<u>the test resumes after:</u>
hide popup and display the percentages of error	maintained push (2 seconds)	INFO key	30 seconds
simply hide popup	simple push	other key	2 minutes

There are three parameters to fill in:

- measurement distance before comparison (in km), common for both tests,
- maximum error for left / right wheel comparison (in%),
- maximum error for GPS and wheel comparison (in%).

This function can be used in two ways:

- monitoring "health" sensors: put a distance short enough to quickly detect a failure (0.15 km for example) and a maximum error large enough to avoid false alarms (5% for example),
- calibration error detection (forget calibration change after changing wheels for example): put a distance long enough to avoid false alarms (0.8 km for example) and a maximum error strict enough to detect small errors (1 % for example).

The given values are indicative and are to be refined before the rally according to the configuration (number of pulses per revolution for example).

5.8 Battery voltage monitoring

The battery voltage is displayed in the link screen.

In case of low or high battery level, a warning popup is displayed in the main running screens. The ignition thresholds can be changed in the alerts configuration page and the red led can follow the display of the popup:

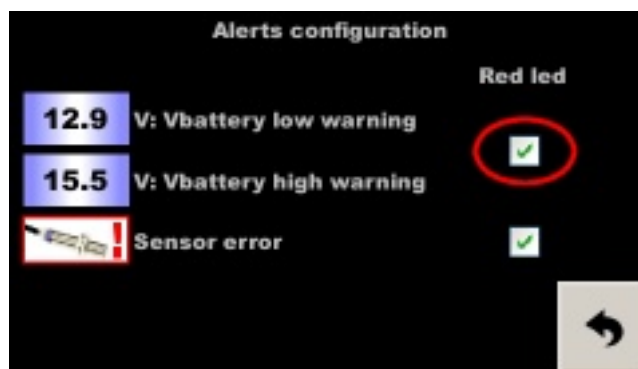

Menu - Config. equipment - Alerts config.

6 Operating modes

This system has 3 operating modes, to be chosen at the bottom of the main menu, depending on the co-pilot's experience.

6.1 *Begginer*

This mode displays a help grid to know the different sensitive areas.

It hides certain complicated parameters:

- clock shift,
- setting the number of km / h by buzzer beep,
- conditions of lighting of the bargraph,
- number of meters added / removed with each press on button box ...

Attention: the **automatic start of the chrono can only be done on each full minute.**

6.2 *Confirmed*

Mode to be used as soon as the user feels comfortable with the machine to take full advantage of it.

6.3 *Expert*

This mode deletes the help buttons and adds a history of distance modifications, manual or automatic (GPS).

7 USB drive usage

Important:

It is strongly recommended to format your USB drive on the device before using it. This function erases ALL data and then formats and conforms it for use with this device.

To access this function, in the main configuration page, press the button with the USB drive:



Attention:

- this operation erases ALL the data present on the key, even if they were written with a computer or a tablet,
- it is advisable to wait ten seconds after the end of the operation, when the display asks to remove the key.

8 Infrared remote control

The decimal point is obtained with the key at the bottom right for Philips (formerly "reset to 0" or "---") or left for OneForAll:



As soon as the remote control is used, frames in red, green, yellow, blue appear in certain areas or buttons. These zones are activated by pressing the corresponding function keys on the remote control:



8.1 Freeze / change distance

To freeze the distance, use the **OK** key. this value can be changed with the number keys or with +/- 1 or +/- 10 m. The new value appears in blue and the difference in green. When validating with the **OK** key, the difference is applied, that is to say that the trip takes into account the distance that runs during the time of manipulation:

14.226	frozen value
14.235	new value
0.009	difference

Example:

- freeze distance to 14,226 km. in front of a sign,
- on the road-book is written 14,235 km for this panel. We type this value,
- valid further at km 14.600, the trip goes to 14.609 km applying the difference.

Notes:

- the difference display (in green) may be hidden in the co-pilot page configuration.
- the frozen value is displayed in meters as part of the command history, bottom right, and during the race, it is saved in the trace file (preceded by the letter F), if this action is not canceled with **BACK** or **EXIT** key.

8.2 New distance

To force a new distance, use the numeric keypad and then valid with the **OK** key.

Example:

- on the road-book is written 14,235 km for a sign. We type this value before reaching the sign,
- valid in front of the panel, the trip passes to 14.235 km applying the new value.

8.3 Managing ZRs with the remote control

To change the ZR, use the green and yellow keys.

To program the distances / speeds in ZR, use the arrow pad to move the active box, then simply type the distance or speed and validate with "OK" key:



Save with the red key.

9 Entering a distance on the fly

In the case that a shift distance is not given before departure, but "at the sign", proceed as follows:

- by preparing the ZR, put a longer distance,
- start the ZR normally,
- before arriving at the sign, open the page with the distances / speeds table,
- with the IR remote control: place on the corresponding box at the end of the segment (a blue frame appears on the pictogram of Trip1 in the bottom left), then press the blue key passing in front of the sign:

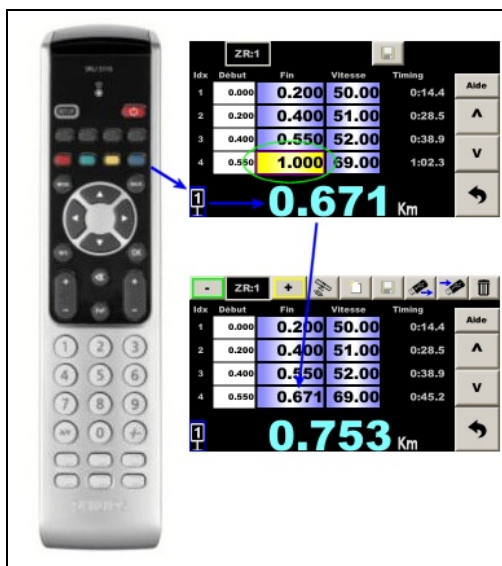

The timer saves the new distance and updates the lead / delay.

Maybe change the speed if it was written on the panel, **but be careful, the new speed is on the next line!**

Save this speed change (red key on the remote control): the timer recalculates the timing and updates lead / delay with new speed, then return to the main screen.

Tip: you can access this page directly from the main page by the yellow key on the remote control.

- with the touch screen: tap on the box corresponding to the end of the segment, the virtual keyboard opens with a special key with the pictogram of Trip1, then press this key passing in front of the panel:



If necessary, modify the speed if it was written on the panel, **but be careful, the new speed is on the next line!**

Save the modification (floppy button): the timer recalculates the timing and updates the lead / delay. Then return to the main screen.

10 Shifted start

In some rallies, the Regularity Tests are "included" in the links, ie the distance is not reset to 0 from the RT start.

10.1 Function activation

To do this, check the box "**Shifted start**" in "**Guidance options**". By doing this, the Trip1 is not set to 0 automatically when the timer starts and the timer takes into account the distance to the counter at the start for his calculation for lead / delay.

10.2 Average speeds changes since the beginning of the road book

Generally, the distances of the average changes are given starting from beginning TC of the section of the road-book, and not from the beginning of the RT as usual.

It is then necessary to check the box "**Km from start RB**" located under the table of distances / averages.

Warning: this box only appears in **Expert mode**.

We must fill the distance boxes with the km that do not start at 0, even if the distance indicated in the first box (not modifiable) is 0. This is not a problem, because what matters is the km end of the first segment, the one that gives the first change of average.

Example:

- departure from the RT to 28.5 km at 49.00 km / h
- change of average to 30.0 km (after 1.5 km) at 50 km / h
- change of average to 32.0 km (ie after 2 km) at 45 km / h
- end at 35.0 (after 3 km) km

Se	Début	Fin	Vitesse	Timing	Aide
1	0.000	30.000	49.00	36:44.0	
2	30.000	32.000	50.00	39:08.0	▲
3	32.000	35.000	45.00	43:08.0	▼
4	35.000	0.000	0.00		↻

Km depuis début RB (pas départ du chrono)

28.500 Km

Note: timings must not be taken into account.

10.3 Average speeds changes since the beginning of the RT

In some rallies, even if the Trip1 is not reset to 0, the average changes distances can be given from the beginning of the RT, when the timer is started. This is the case if the starting point is secret (not indicated in the road book).

Example: distances / speeds idem previously:

Se	Début	Fin	Vitesse	Timing	Aide
1	0.000	1.500	49.00	1:50.2	
2	1.500	3.500	50.00	4:14.2	▲
3	3.500	6.500	45.00	8:14.2	▼
4	6.500	0.000	0.00		↻

Km depuis début RB (pas départ du chrono)

28.500 Km

11 MultiSpeeds mode

In this case the co-driver must enter distances and times of passage (instead of average speeds). The table can be given by the organizer in advance or just before the start of the regularity test.

In the classic mode, end of segment timings are given as an indication. In the multi-speeds mode, you can enter them, **but only on the remote control** in this version.

Check the box at the top right:



After entering the distance, the cursor automatically switches to the time entry box. You have to enter:

mm:ss.t

- mm: minutes beginning with 0 if less than 10 mn
- ss: seconds
- t: tenth of a second that can be omitted if 0

Once the timing is entered, the timer takes into account the segment, it calculates the average speed and refreshes the lead / delay, it is not necessary to record with the red key.

It is possible to enter the average speed as the conventional mode if the table mixes speeds and times of passage but in this case, it is necessary to record with the red key so that the timer calculates the times and updates lead / delay.

In summary:

**distance by blue key or multi-speeds timing: no need to record to take into account
entering or changing average speed: red key record required**

12 Recordings

This equipment records files during the race.

It can also record several files during scouting:

- GPS trace in two formats,
- correction waypoints for GPS auto-correction.

12.1 Regularity Tests recording

As soon as the stopwatch is triggered, a file is recorded into the internal flash disk. Its name is the start number, the RT number, date and hour. The format is the following:

S	10				
V	4500				
P	14:26.0	0	44.7522823	4.2335585	0
...					
P	14:39.7	17962	44.7514067	4.23258083	-74
G	4				
M	42587				
D	5				
A	-10				
C	10				
F	42697				

First column is a label indicating the type of data:

- S: Start of RT, then the index of the RT. Here ZR10,
- V: speed imposed in 1/100 km/h. Each speed imposed changement is recorded. Here 45.00 km/h,
- F: the co-driver froze at this distance, in meters,
- D: GPS advise, in meters. Here the GPS advises to add 5 meters to Trip1,
- G: GPS auto-correction, in meter. Here GPS added 4 meters to Trip1,
- W: GPS auto-correction waypoint missed, then the index of the waypoint,
- M: manual set, in meter. Here the copilote set Trip1 to 42.587 km,
- A: manual (relative) adjustment. Here the copilote subtracted 10 meters to Trip1,
- C: operation Cancel in meter. Here the copilote cancel the '-10 m' so he added 10 meters,
- P: gps Position and more:
 - time-stamp: Minute:Second.Tenth, here 14 minute and 39.7 seconds
 - distance in meter, here 17.962 km,
 - latitude in degrees, here 44.7514067° North (44°45'05.1"N),
 - longitude in degrees, here 4.23258083 East (4°13'57.3"E),
 - delay calculated by timer in 1/100 second, here 0.74 s. advance.

Remarque : latitude longitude can be copy/pasted in GoogleMap (after removing « ; »).

The files are copied automatically in a USB drive when inserted, then archived (see later §).

12.2 GPS trace during scouting

Two GPS traces can be recorded (**outside of race**) when enabling the recording function.



To access this function, in the main menu, push the USB drive button

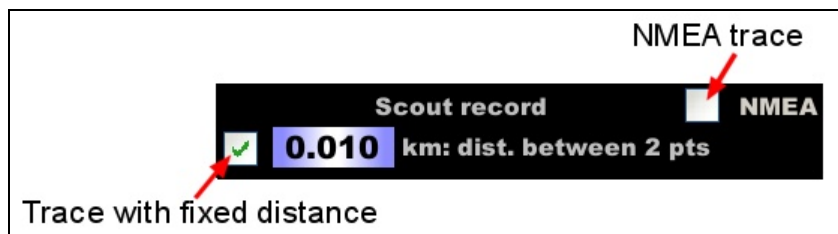

The recording **starts and the files are created when Trip1 is reset to 0**. A red point pictogram appears on the screen.

The recording stops when stopwatch is armed (no need to trigger, just arm). *A more friendly stop function is to be added to firmware.*

The files are copied automatically in a USB drive when inserted, then archived (see later §). They can be visualized and/or converted in different formats, for example with:

GPS Visualizer see <http://www.gpsvisualizer.com/>

12.2.1 Traces with fixed distance

It is a trace that records a point after driving a configurable distance. This distance gives the precision but also the weight of the generated file. 10 m is a good compromise between accuracy and size.

In the **Recording** page, push the button on the left and enter the desired distance between 2 points recorded for the “fixed distance” trace. It is interesting to record this trace during GPS auto-correction waypoint recording. It associates waypoints with distance on every wheel. Then it allows to add correction points in the GPS waypoints file, after the end of scouting, once back in office.

File name is: **Scout_date_hour.csv**

The format is the following:

GMT Hour	Left	Right	AuxLeft	AuxRight	Lat	Lon
134304	0	0	0	0	45.0149405	5.63988717
134347	0.01	0.01	0.01	0.01	45.0148463	5.63988683
134349	0.02	0.02	0.02	0.02	45.0147582	5.63988

- **GMT Hour** is the time-stamp from the GPS. In France, add one hour in winter and 2 hours in summer.
- **Left** and **Right** distances are the main sensor input distances (non driving wheel),
- **AuxLeft** and **AuxRight** distances are the auxiliary sensor input distances (often driving wheel).

Note: **Aux** check box has to be checked in “car configuration wheel choice”. *In this firmware version, only “Peugeot/Citroën ABS” OBDII configuration is compatible with function,*

- latitude and longitude in degrees. Can be copy/pasted in GoogleMap (after removing « ; »).

12.2.2 Traces with fixed time (0.1 second)

An **NMEA trace** (historical GPS protocol) can be recorded checking the check box on the upper right corner. Raw data from the GPS are directly recorded, so 20 lines every seconds! This trace is not concern by Trip1 distance and can be used to simulate the GPS on desk or can be converted in GPX or KML file. It is not recommended to record this trace during scouting if you stop often to hand write landmarks because the files become huge.

File name is: **GP_date_hour.csv**

12.3 Correction waypoints during scouting

Please see annexe document for this function. GPS auto-correction option is needed.

12.4 File copying and archiving

Once a USB drive is inserted in the USB socket, the files copy is launched and a popup windows is displayed during the copy:

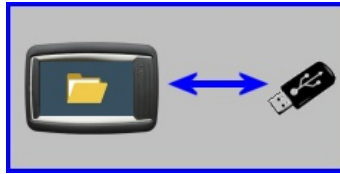

This operation copies the following files:

- ZRxx_date_hour.csv: RT data,
- Scout_date_hour.csv: scouting data (with one record every 10 metres for example),
- GP_date_hour.csv: NMEA scouting data (with 10 position records every seconds),
- other files used for firmware logging, do not concern.

Please wait after the USB drive “operation” led to be off or about 5 seconds if the USB drive has no led to remove the USB drive.

Once the USB drive is removed, the files are compressed, archived to internal drive in case of problem with USB drive. The format of archive file is .tar.gz (linux format, can be unpacked with IZArc, 7-Zip, WinZip...). Then the original files are erased from internal disk.



In the bottom of **Recording** page, accessed pushing the USB drive button in the main menu, you can see the number of files to be copied, the number of archive files and the disk space used:



Insert a USB drive in the socket then push on the left button to access a page to:

- copy the archive files if needed (if files on USB drive have been lost),
- delete the archive files.

After each race, the archive space should be cleared to free internal flash disk!

13 "Gravel crew" notes announcement

This function is used to announce the notes taken by the "gravel crew" as follows:

- display of the note in a popup window with a yellow background on the co-pilot screen:



- display a popup with a panel on the RP380 driver screen (with program version 190122 or later):



For: water runoff or snow / ice or "Not rope" respectively

- with HUD module Led6: yellow flash + long beep.

The notes are taken by pressing a button (or remote control with corresponding numerical key):

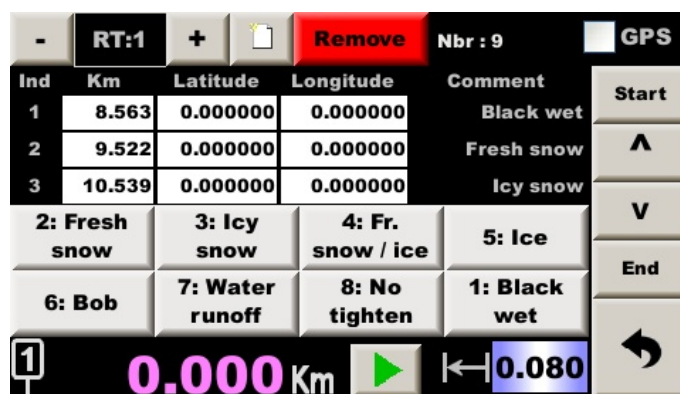

Bottom middle: mode change button (red dot: recording of notes, green triangle: reading).

Bottom right: distance at which the note is announced before arrival on the difficulty.

Top right: add GPS coordinates to the file. Not necessary, see annoying for readability if the file is sent via SMS.

The function is accessed by the button located in the ZR management screen:

14 Firmware updates

The program update includes the files **application.tar.gz** and **application.tar.gz.md5**.

You have to copy these two files on a USB drive, so that you have them at the "root" of the drive.

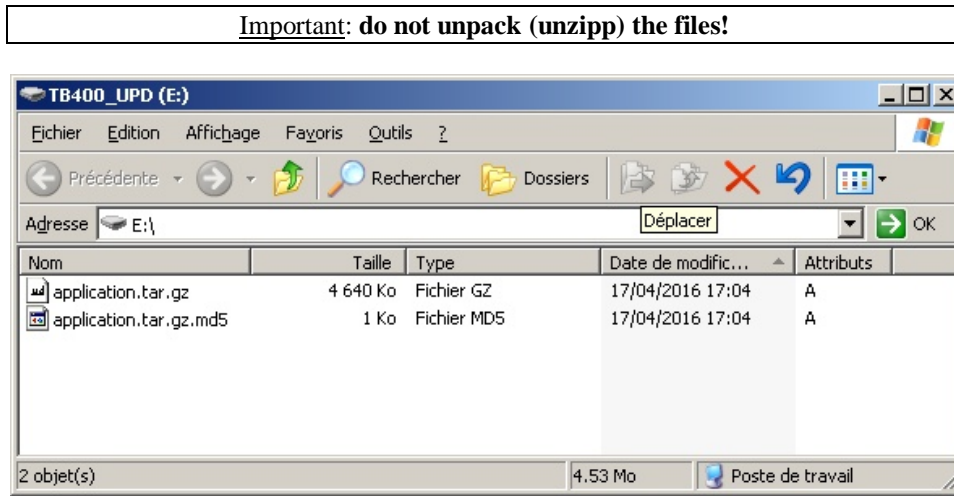

Insert the USB drive into the connector, the dash read it. In the configuration screen a button appears **if both files are found at the "root" of the drive**:



Press this button to go to the system update screen and press the button corresponding to the desired update:



Display goes to the following bleu screen:

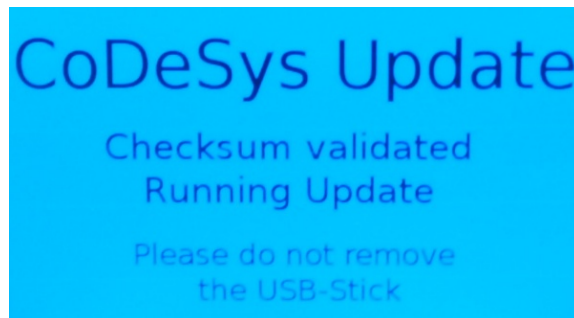

Do not cut the power or remove the USB drive!
After a few seconds, it goes to the following screen:

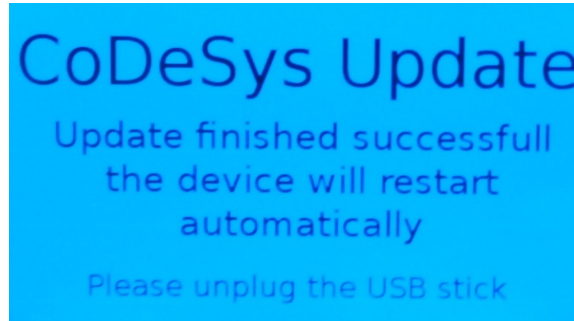

The USB drive can be removed, the program restarts.

Note: on RR420, these two blue screens can be displayed upside down, this is not an anomaly.

15 Welcome picture update

Prepare a file with 480 * 272 pixels size and .PNG format. The name must imperatively be "**logo.png**".

Place this file on a USB drive formatted in FAT32 (in the root).

Insert the USB drive into the connector, the display reads and updates the welcome picture (first and longest part only).

Note: on RR420, picture has to be drawn upside down.